

Weld ring centrally to form 'T' ring

Hub: Cast Iron, Profile as cast  
 Bearing: Bronze or Brass  
 Cap: Iron or exceptionally Brass

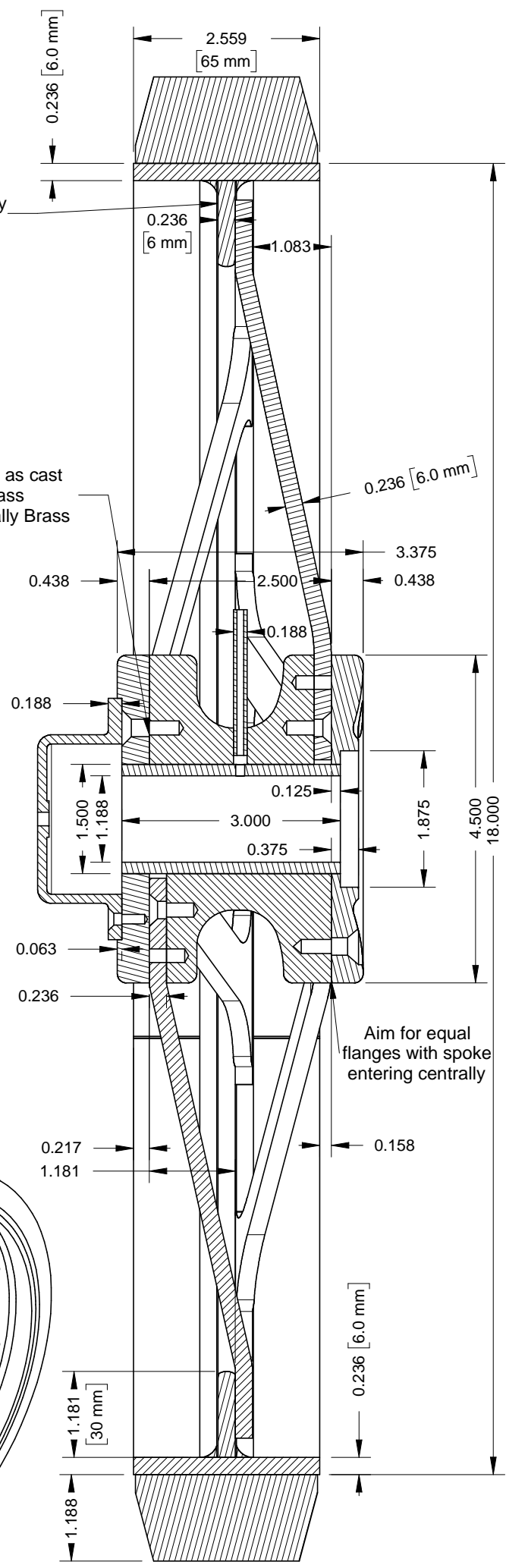

Aim for equal flanges with spoke entering centrally

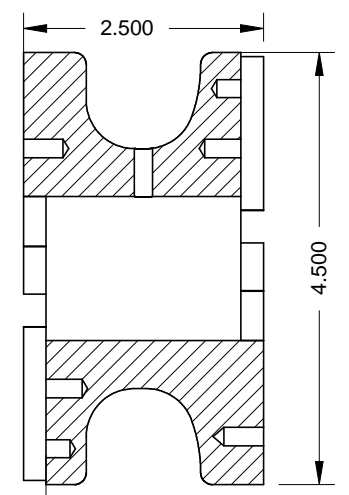
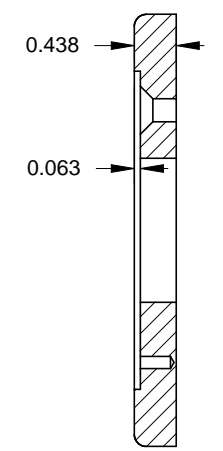
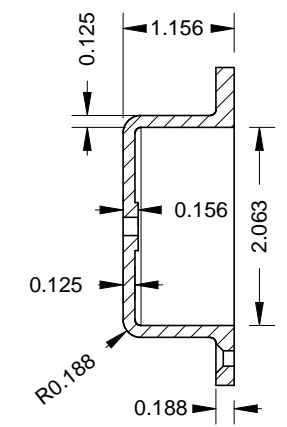

$0.236$   
 Min dim  
 Enshure spoke  
 is not proud

